

# Knowledge



Name \_\_\_\_\_

Form \_\_\_\_\_



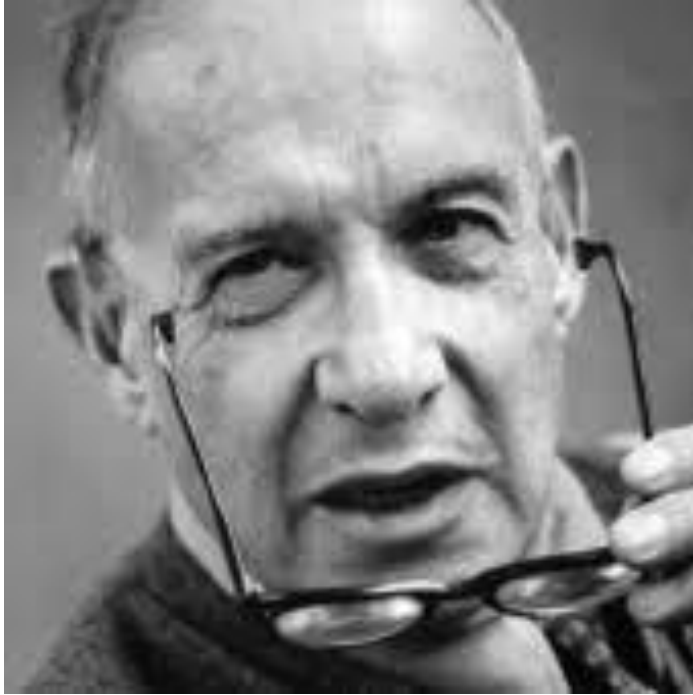

"Today knowledge has power. It controls access to opportunity and advancement."

Peter Drucker

*(research 10 facts about Peter Drucker)*

Year 8 Knowledge Organiser: Term 1B

# Instructions for using your Knowledge Organiser

The timetable on the next page tells you which subjects you should be studying on which days (**it doesn't matter if you have that subject on that day or not, you should follow the timetable**).

You are to **use your exercise book** to show the work you have done. Each evening you should **start a new page** and **put the date clearly at the top**.

You need to **bring your KO and exercise book with you EVERY DAY** to school. Your KO and exercise book will be checked regularly in form time.

You will also be tested in your lessons on knowledge from the organisers.



You must use the revision strategy **Look - Say - Cover - Write - Check** to learn the knowledge. You can also use your KOs and book in a number of different ways but you **should not just copy** from the Knowledge Organiser into your book.

## Presentation

You should take pride in how you present your work:

- Each page should be **clearly dated at the top right hand side** with the **Subject written in the middle e.g. English**.
- Half way down the page **a line should divide it in two** with **Next Subject e.g. Maths written above** the dividing line.
- Each half of the page should be **neatly filled with evidence of self-testing**. There should be an appropriate amount of work.
- **Failure to show pride in your presentation** or **wasting space on your page** with large writing or starting a number of lines down **will result in a negative ATL**.



# Year 8 Knowledge Organiser Homework Timetable

You are expected to **study the subjects shown on your timetable each day**. You need to **spend 20 minutes on each subject** and you will need to **evidence your work in your exercise book**.

WEEK A	Subject 1	Subject 2	Subject 3
MONDAY	English	Spanish	Geography
TUESDAY	Science	Maths	PD
WEDNESDAY	History	Music	Science
THURSDAY	RE	Maths	Food
FRIDAY	Computing	Technology	English

WEEK B	Subject 1	Subject 2	Subject 3
MONDAY	English	Drama	Geography
TUESDAY	Science	Maths	RE
WEDNESDAY	History	PE	Science
THURSDAY	RE	Maths	Spanish
FRIDAY	Computing	Art	English



# Reading Log

*"The more that you read, the more things you will know. The more that you learn, the more places you'll go"*

*Dr Seuss*

Use this reading log to record the books you read and how long you have spent reading.

Week	MON	TUE	WED	THURS	FRI	SAT	SUN	Book(s) read (title and author)	Time spent reading	Parent comment/signature
Week 1										
Week 2										
Week 3										
Week 4										
Week 5										
Week 6										
Week 7										
Week 8										



# Year 8 English Term 1B: Non-Fiction - School Issues

**Non-Fiction:** A type of writing that is factual and informative instead of make belief.

You will be exploring a range of non-fiction texts about different school related issues. You will be focusing on how writers present their perspectives before producing a piece of writing that conveys your own thoughts and ideas.

## KEY TECHNIQUES

<b>PAFT</b>	Purpose, audience, form and tone	<b>Anecdote</b>	A short amusing or interesting story using examples to support ideas
<b>Purpose</b>	What a text trying to do. Is it informative, advisory or persuasive	<b>Facts</b>	Something which is real and can be demonstrated
<b>Audience</b>	Who a text is aimed at	<b>Opinion as fact</b>	Presenting your opinion in a way which makes it sound real
<b>Format</b>	The type of text (eg: letter, speech, report etc)	<b>Repetition</b>	When words or phrases are used more than once in texts
<b>Tone</b>	The way a piece of text sounds e.g. sarcastic etc. The mood or atmosphere in the writing	<b>Rhetorical Question</b>	A figure of speech in the form of a question that is asked in order to make a point
<b>Hyperbole</b>	Use of exaggerated terms for emphasis	<b>Emotive Language</b>	Words selected to evoke a specific emotion from the reader
<b>Imperative</b>	Commanding and self-confident. Likely to be respected and obeyed	<b>Statistics</b>	The use of numerical facts to support a point of view
<b>Direct Address</b>	Using you, we or us	<b>Three (Power of 3)</b>	Making 3 separate points about an issue

## Writing Tips:

**SPAG** - Applying spelling, punctuation and grammar effectively. Minimum expectations: capital letters, full stops, commas & apostrophes. Challenge: colons, semi-colons, parenthesis, exclamation marks, hyphens.

**Sentence structures** - applying a variety for effect - simple, compound and complex. Using time and sequencing connectives.

**Paragraphing** - TIPTOP rules & being able to apply these effectively.



## Addition

Furthermore

Additionally

In addition

As well as

## Contrast

Although

Whereas

Otherwise

Alternatively

Nevertheless



## Problem Solving at St Cuthbert's

- K** Key Information - Highlight or pick out the important things that you will need
- L** List the Maths - What Maths topics will you need? Can you write down any rules?
- A** Attach Numbers -
  - Assign numbers to help
  - Relate the problem to one you can already do eg..  $3 \times 4 = 12$
- P** Picture -
  - Annotate the diagram given with any information
  - Draw a picture to help you visualise
- S** Sensible - Does your answer make sense?

### Don't forget

Always show your working out  
Never round half way through a question

## Key Words

Take care with your spellings of these key words

Substitute	Expression
Formula	Linear
Function	Probability
Likelihood	



## Substitution

### Algebra Substitution

Evaluate the expression  $h + 5$ , for  $h = 3$

The expression is:  $h + 5$

We need to replace the "h" with 3

This makes:  $3 + 5$

which equals:  $8$  ✓

### Harder Expressions

Evaluate the expression  $2y + 7$ , for  $y = 4$

$$2y + 7 \quad (y = 4)$$

$2y$  means  $2 \times y$

$$= 2(4) + 7$$

$$= 8 + 7$$

$$= 15$$
 ✓

If we are given a formula, we can substitute values into the formula in order to find the solution:

Here is the formula for the area of a rectangle:

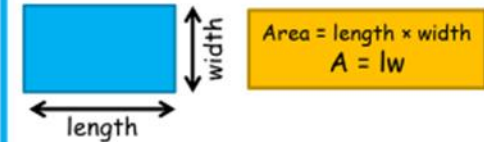

If we know that the length = 5cm and width = 4cm...

Or  $l = 5, w = 4$ ...

We can substitute these values in to find the area.

$$A = lw = 5 \times 4 = 20 \text{ (cm}^2\text{)}$$

This formula calculates Body Mass Index (BMI).

$$BMI = \frac{\text{weight}}{\text{height}^2} = \frac{w}{h^2}$$

It is one way to measure whether a person is a healthy weight or not (a BMI between 18.5 and 25 is considered healthy).

If a person was 1.6m tall, ( $h = 1.6$ ) and weighed 60 kg... ( $w = 60$ )

$$BMI = \frac{w}{h^2} = \frac{60}{1.6^2} = \frac{60}{2.56} = 23.4375$$

**Watch Out!**  
Think BIDMAS:  
We need to calculate the power before we do the division.

A BMI of 23.4(ish) is healthy. This person would not need to lose weight (but should be careful not to gain too much more).



## The Probability Scale

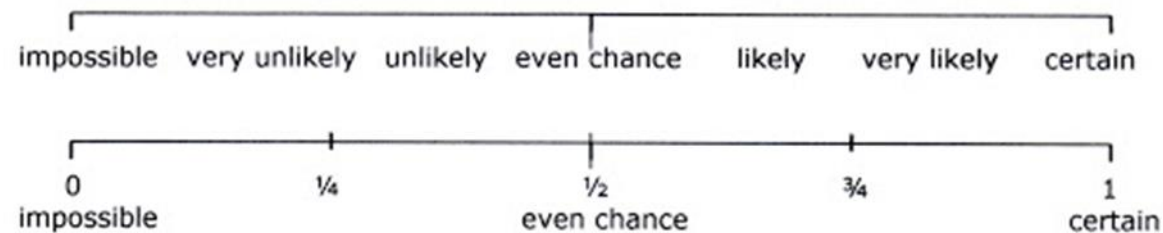

We can place the likelihood of events happening on a probability scale, and these can be expressed using probability words, or fractions or decimals.

If the probability of an event happening is **impossible**, we say it has a probability of 0

If the probability of an event happening is **certain**, we say it has a probability of 1

### **Example:**

A bag contains 3 red counters and 5 green counters. I pick a counter out of the bag at random.

The probability of picking a red counter is  $\frac{3}{8}$

The probability of picking a green counter is  $\frac{5}{8}$

I am more likely to pick a green counter than a red counter, as I have a 5 out of 8 chance of picking green

### **As Decimals:**

We can also give probabilities as decimals.

If we are told the probability of it raining tomorrow is 0.3, then the probability of it NOT raining is 0.7

The probability of an event happening + the probability of it NOT happening will be equal to 1, as it is certain that one of those events will happen.



# Year 8 Science - Term 1B

## Key Words

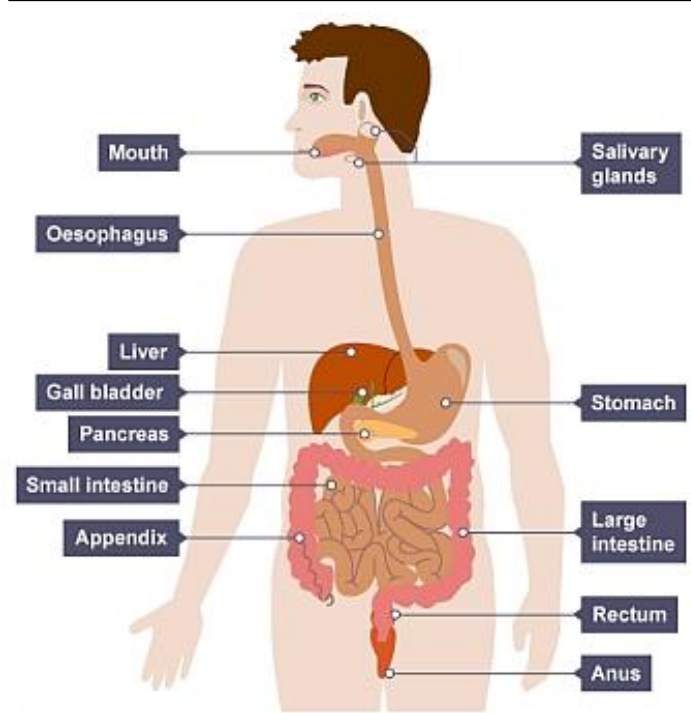

What are you testing for?	Which indicator do you use?	What does a positive result look like?
Sugar	Benedict's reagent	Once heated, the solution will change from blue-green to yellow-red
Starch	Iodine	Blue-black colour indicates starch is present
Protein	Bluret	The solution will change from blue to pink-purple
Lipid	Sudan III	The lipids will separate and the top layer will turn bright red

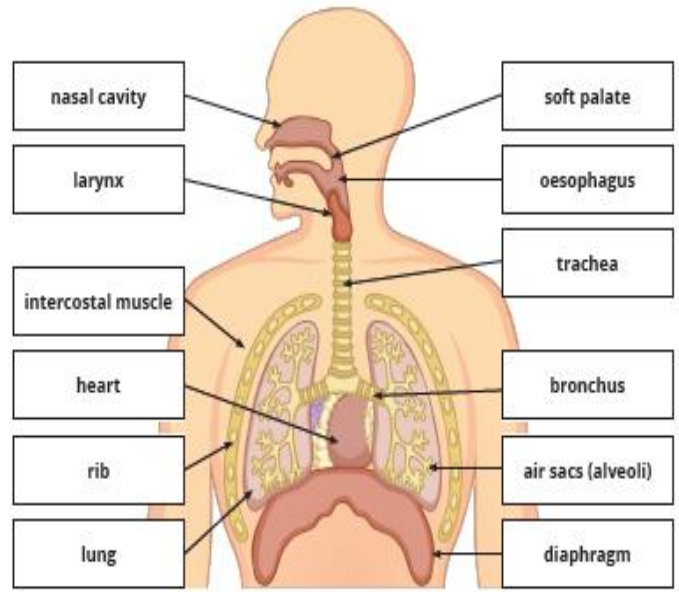

<b>Enzyme</b>	Biological catalysts which speed up reactions
<b>Denatured</b>	When the shape of the active site changes
<b>Active site</b>	Where what the enzyme is working on fits the enzyme
<b>Digestion</b>	The breakdown of food into soluble molecules
<b>Respiration</b>	glucose + oxygen → carbon dioxide + water
<b>Breathing</b>	The process where air travels into and out of the lungs

There are 3 types of enzymes in digestion:

- protease;
- amylase;
- lipase.

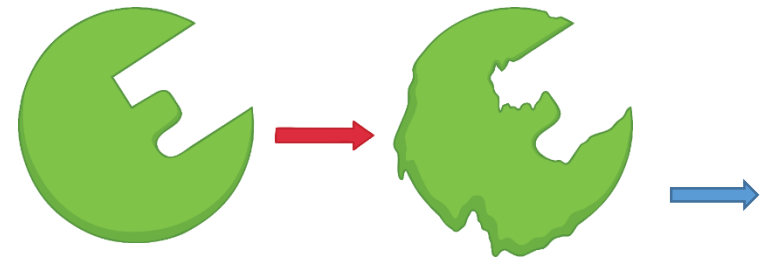

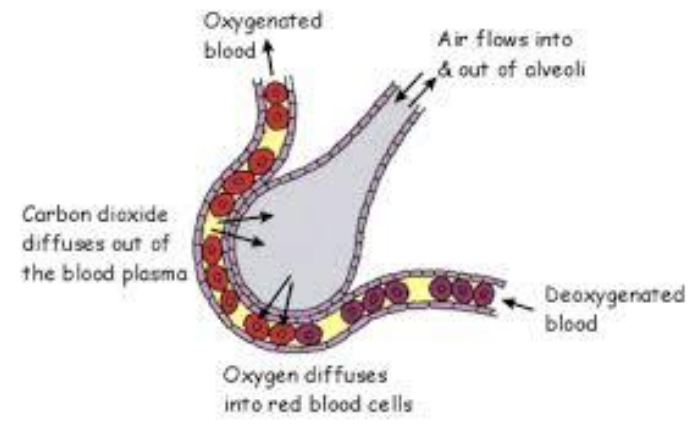

Enzymes are very specific and will only work under certain conditions. If the conditions change too much the enzyme will become denatured. This means the enzymes change shape and the active site no longer works. Conditions that affect the enzyme include temperature and pH.



### The 7 Food Groups?

1. Carbohydrates
  2. Proteins
  3. Fats
  4. Vitamins
  5. Minerals
  6. Fibre
  7. Water
-

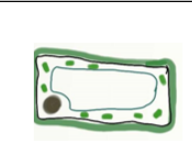
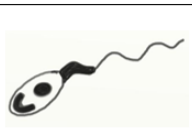
# Year 8 Science - Term 1B

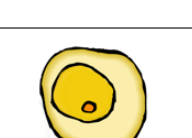
	<b>A Palisade Cell</b>	<b>Found in:</b> A plant leaf	<b>How it is adapted:</b> Lots of chloroplasts for photosynthesis.
	<b>A Sperm Cell</b>	<b>Found in:</b> Human testis	<b>How it is adapted:</b> It has a tail for swimming.
	<b>A Red Blood Cell</b>	<b>Found in:</b> Human blood	<b>How it is adapted:</b> It does not have a nucleus so there is more space to carry oxygen.
	<b>An Egg Cell (ovum)</b>	<b>Found in:</b> Human ovaries	<b>How it is adapted:</b> It has a large store of food for the growing embryo.

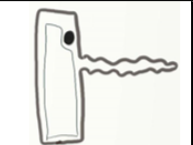
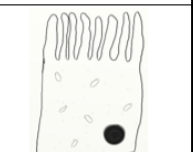
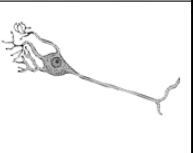
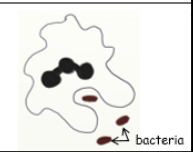

	<b>A Root Hair Cell</b>	<b>Found in:</b> A plant root	<b>How it is adapted:</b> Long outgrowth to take up lots of water.
	<b>A Ciliated Epithelial Cell</b>	<b>Found in:</b> Human noses and lungs	<b>How it is adapted:</b> It has cilia (tiny hairs) used for moving along harmful particles (e.g. dust).
	<b>A Nerve Cell</b>	<b>Found in:</b> Everywhere in the human body	<b>How it is adapted:</b> It is very long so can carry messages (e.g. pain) up and down the body.
	<b>A White Blood Cell</b>	<b>Found in:</b> Human blood	<b>How it is adapted:</b> It is able to 'eat' microbes to protect the body against disease.

## Key Words

<b>Specialised cell</b>	Cells that have developed certain characteristics to perform a particular function.
<b>Differentiated</b>	When cells become specialised.
<b>Reproduction</b>	The process of producing offspring.
<b>Function</b>	Job of the cell.
<b>Adaptation</b>	A characteristic that makes a cell suited to its function.

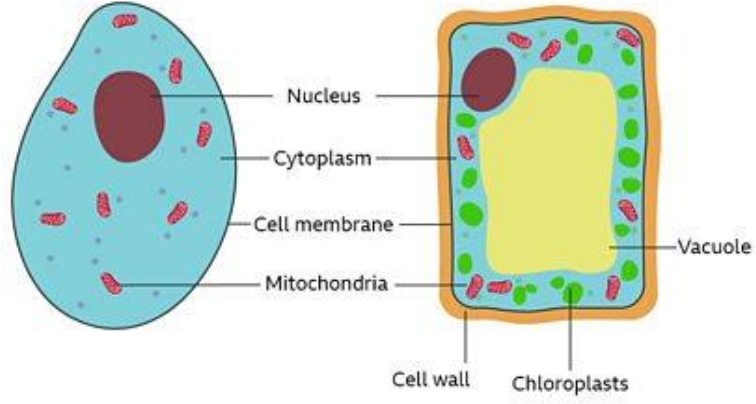

Male Reproductive System

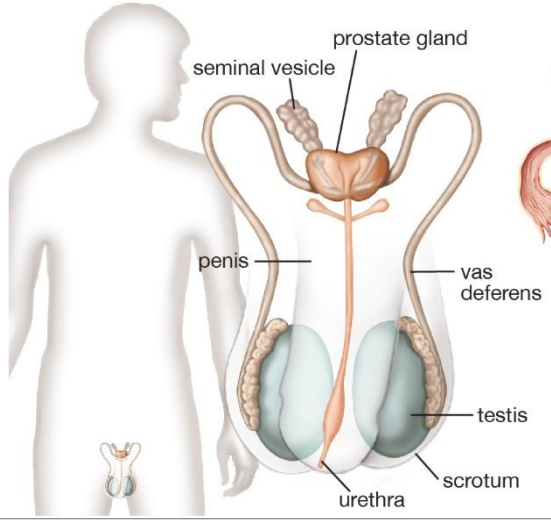

Female Reproductive System

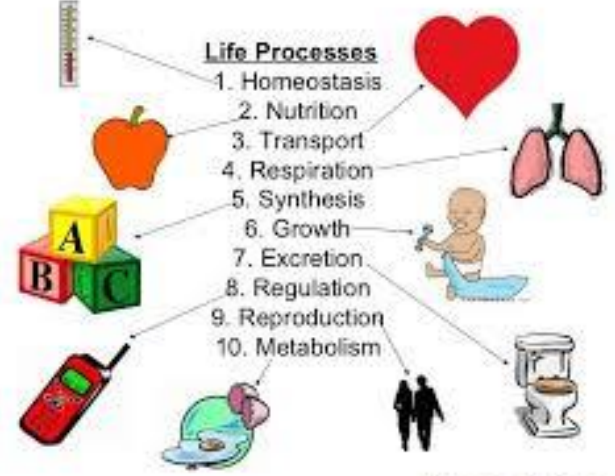
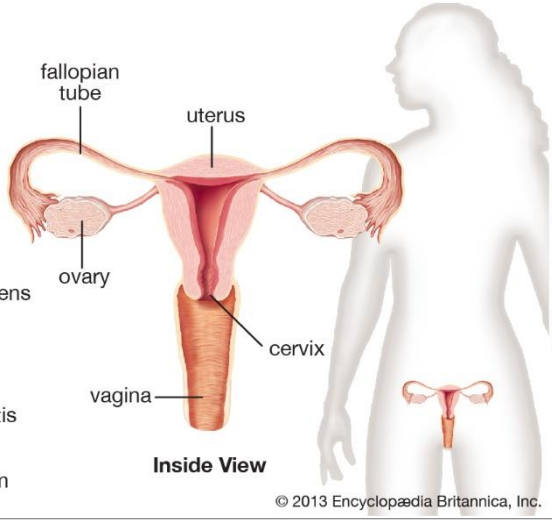

# Year 8 Religious Education - Term 1B:

## The Covenant Story Continued

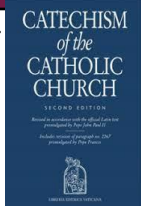

### Some big questions we will be thinking about...



- ✓ What is the sign of the Mosaic covenant and is it important today?
- ✓ What was the message of the Old Testament prophets? Are the prophets still relevant today?
- ✓ What do Jews believe about the Messiah?
- ✓ How did John the Baptist prepare the way for Jesus?
- ✓ Who was Jesus?
- ✓ Why are Jesus' miracles important?
- ✓ What and why did Jesus teach in parables?

### Essential knowledge

**A covenant** is an promise with duties on both sides. The relationship between **God and God's people** in the Old Testament is a covenant. Christians believe our relationship with God today is still based on **God's unconditional love** and our response in **faith**.

A prophet is a messenger of God.

Prophets were chosen by God and called to proclaim God's message to the people and call the people back to the **Covenant, the loving relationship with God**.



They would remind the people how to behave and warn them about what would happen if they didn't listen!

**The Messiah is a key belief in Judaism and links to a time of peace and justice. The Jewish people were waiting for the Messiah - many believed Jesus of Nazareth was the messiah, but many others disagreed.**

For Christians, Jesus established the new covenant when he was baptised in the River Jordan, by John the Baptist, who had been telling people to turn to God and that the saviour would come.

For Christians Jesus was the incarnation - God made into flesh. He was fully human and also fully divine. He performed many miracles, which teach Christians about his divinity. He taught in parables.

Key Words	Definition
Covenant	A promise or agreement between two parties. Covenants were made between God and His people.
New Covenant 	Christians believe Jesus is the new covenant because he shows God's unconditional love finally and fully. Jesus is God's love.
Messiah	Literally meaning the anointed one. The promised one sent by God. 'Christ' in Greek.
Prophets	Messengers of God. Amos, Jeremiah, Isaiah and
Shema <b>שמע ישראל</b> Sh'ma Yisra'eil Hear, Israel	Important Jewish prayer; describes the Jewish belief that there is 1 God.
incarnation 	'made flesh' -the belief Jesus is God. He was fully God and fully human.
miracles	Events that cannot be explained by science; they are believed to be the work of God.
parable	An earthly story with a heavenly meaning. Jesus taught in parables.
mitzvot	613 rules or duties for living given to Moses by God.
mezuzah 	Small box on the doorframe of Jewish houses and synagogues; contains the Shema prayer on a small scroll.

Sources of Wisdom and Authority (SOWAA)
'Thanks to the prophets, Israel understood that It was again out of love that God never stopped Saving them and pardoning their unfaithfulness and sins' - Catechism of the Catholic Church
 And this was his message: "After me comes the one more powerful than I, the straps of whose sandals I am not worthy to stoop down and untie. I baptise you with water, but he will baptise you with the Holy Spirit." - John the Baptist - Mark 1:7-8
'Hear o Israel , the Lord is our God, the Lord is one -Shema prayer in the Torah
'the word was with God, and the word was God...and the word became flesh and lived amongst us' - John's Gospel 
 'this is my beloved son...with whom I am well pleased' Jesus' baptism - Matthew 3:13-17
<b>The parable of the sheep and the goats;</b> - 'Whoever does this for the least of my brothers and sisters he does to me' - Matthew 25: 31-46
<b>The parable of the lost son;</b> 'this son of mine was dead and is alive again; he was lost and is found' - Luke 15:11-32
<b>The parable of the Good Samaritan;</b> 'love your neighbour as yourself' - Luke 10: 25-37
<b>Jesus heals the paralysed man;</b> 'your sins are forgiven.....get up, take your mat and go home' - Luke 5:17-26



# Year 8 Geography - Term 1B: Africa

## Key locations...

## Picture this...

### Key Vocabulary...

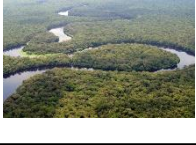
<b>Perceptions</b>	Your perception of something is the way that you think about it or the impression you have of it.
<b>Colonisation</b>	Colonization is the act of setting up a colony away from one's place of origin. Colonization is sometimes seen as a negative act because it tends to involve an invading culture establishing political control over an indigenous population (the people living there before the arrival of the settlers).
<b>Biomes</b>	A biome is a large region of Earth that has a certain climate and certain types of living things.
<b>Desert</b>	A large, dry, barren region, usually having sandy or rocky soil and little or no vegetation. Less than 25 cm of precipitation each year,
<b>National Reserve</b>	A nature reserve, is a protected area of importance for plants and animals, or features of geological or other special interest,
<b>Tropical Rainforest</b>	The tropical rainforest is a hot, moist biome found near Earth's equator. The world's largest tropical rainforests are in South America, Africa, and Southeast Asia. Tropical rainforests receive from 60 to 160 inches of precipitation that is fairly evenly distributed throughout the year

<b>Sahara Desert</b>		The Sahara is a desert located on the north of the African continent. It is the largest hot desert in the world.
<b>Congo Rainforest</b>		The Congo Basin Rainforest is located in the central and western part of equatorial Africa. It is the world's second largest rainforest. The Congo Rainforest makes up 18% of the world's remaining tropical rainforest.
<b>Savannah Grassland</b>		Savannas are generally found between the desert biome and the rainforest biome. They are mostly located near the equator. The largest savanna is located in Africa. Nearly half of the continent of Africa is covered with savanna grasslands.



### The BIG questions..

1. Describe where different biomes can be found in Africa?
2. Do you think Colonisation has hindered Africa's development? Discuss your answer.

### Back in time...

The British colonized Africa in about 1870. When they heard of all of Africa's valuable resources such as gold, ivory, salt and more, they did not hesitate on conquering the land. They wanted these resources because they needed them for manufacturing. Another resource in Africa was rubber which was very helpful and used in making many good-selling items like shoes. Great Britain ruled present day Sudan, Kenya, Botswana, Lesotho, Egypt, Northern Somalia, Eastern Ghana, Benin, Gambia and Niger.

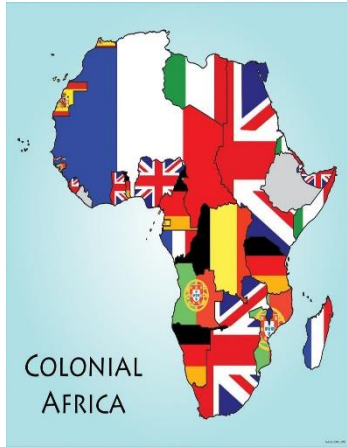

### Deeper Learning...

WILD ANIMALS ARE being poached on a massive scale, with millions of individual animals of thousands of species worldwide killed or captured from their native habitats. Poaching poses a growing threat to elephants, rhinos, and other charismatic animals, as well as to smaller and more obscure creatures, like certain lizards and monkeys.

Activity: Create your own species of an African animal that could live in either 1. A tropical Rainforest 2. The Hot Desert or 3. The Savannah Grassland. Remember it must be able to survive in the conditions of its habitat.

# Year 8 History - Term 1B: The Tudors

House of Tudor, an English royal dynasty of Welsh origin, which gave five monarchs to England: Henry VII (reigned 1485-1509); his **1** son, Henry VIII (1509-47); followed by Henry VIII's three children, Edward VI (1547-53), Mary I (1553-58), and Elizabeth I (1558-1603).

**3** **Key vocabulary:**

**Catholic:** Catholics base their beliefs on the Christian Bible.

**Protestant:** a Christian who belongs to the branch of the Christian church that separated from the Catholic church in the sixteenth century.

**Monarchy:** A form of government that has a single person known as a monarch at its head.

**Reformation:** A period of major religious change and conflict across Europe in the 1500s.

**Monasteries:** a building, or buildings, where people lived and worshiped, devoting their time and life to God.

**Heresy:** a word used by different religious groups, used to describe someone who has ideas that are different from what the religion or law.

Date	Event
1485	Henry VII is crowned
1502	Arthur, the heir to the throne dies
1509	Henry VIII becomes king
1534	Act of Supremacy is passed making Henry Head of the Church of England.
1536	Act of Union joins Wales to England
1544	Henry invades Northern France
1545	Mary Rose sinks fighting the French in Portsmouth Harbour
1547	Edward VI becomes King
1553	Mary I becomes Queen
1558	Elizabeth 1 becomes Queen
1570	Drake sails around the world
1587	Mary, Queen of Scots is executed
1588	Spanish Armada
1603	Death of Elizabeth. She hands the thrown to her cousin James Stuart.

**2**

Henry VIII and the Reformation

Henry VIII had been a devout Catholic in his younger years. He had defended the Pope against the Protestant ideas published by Martin Luther, a German priest.

In 1534, Henry declared that he, not the Pope, was the head of the Church in England. This sparked the English Reformation.

The break with Rome eventually triggered England's transition to being a Protestant country.

The Reformation had major repercussions, including the Dissolution of the Monasteries and many rebellions.

**4**

## Mary 1

5

The daughter of Henry VIII and Catherine of Aragon, Mary I, was the first queen of England who ruled from 1553 until her death in 1558. During her brief reign, she mainly aimed to restore Catholicism in an mostly Protestant England and provide an heir to the throne helped by her marriage to Prince Philip of Spain. She was popularly known as 'Bloody Mary' due to her religious policy that persecuted (mistreated) numerous Protestant heretics. She remained childless and later accepted her half sister Elizabeth as her successor/replacement.



## The Spanish Armada

6

12th July 1588 The Spanish Armada sets sail from Spain.

19th July 1588 The English see the Armada. After seeing the Armada ships, English ships chase them up the English Channel.

27th July 1588 The Armada anchors off Calais. The English send burning ships at the Armada. The Spanish panic!

28th July 1588 English ships attack the Armada near Gravelines in the Netherlands. As the Spanish sailed off from Calais they were attacked by the English. This meant that they could not stop to pick up more soldiers waiting for them in the Netherlands.

30th July 1588 The Armada tries to make it back to Spain by going around the coast of Scotland.

AUGUST Fierce storms off Scotland and the west coast of Ireland wreck many Spanish ships.

SEPTEMBER Only two-thirds of the Armada war ships make it back to Spain.

7

## The Black Tudors

People of African origin came to be in England via a range of routes. Some came as traders and ambassadors, some directly from the continent of Africa, while others arrived via the Spanish and Portuguese empires.

John Blanke was a Tudor musician. Historians believe that he may have come to England alongside Catherine of Aragon, as part of her household staff. John was employed by Henry VII and Henry VIII; there is evidence to show that he performed at both the funeral of Henry VII and the coronation of Henry VIII.

Will Sommers served Henry for most of his reign as a Fool/Jester. He was trusted by Henry, appearing in the Tudor family portraits. He was given a carer when he retired to look after his financial needs and an income. Fool/Jesters were seen as pure and without deceit/dishonesty.

8





## Understanding payslips

Payslips are very important and, as you just saw, they include information that you need to understand and check.

Employer's Name: Selling Is Us	Employee Number: 31	Employee Name: Ollie
Pay Method: Electronic	Account no: 876543210	Sort Code: 110011
Tax Period: 6	Tax Code: 1060L	NI Number: BB001122E
		From: 09.2016
<b>THIS PERIOD</b>		
Gross Monthly Pay:	£1920.00	
<b>THIS PERIOD</b>		
National Insurance:	£149.80	
Income Tax:	£200.67	
Student Loan:	£15.30	
Total Deductions:	£365.77	<b>NET PAY</b>
<b>YEAR TO DATE</b>		
Total Pay:	£11520.00	
Deductions to Date:	£ .....	

Your personal details

Gross pay

Net pay

Deductions

How do I understand payslips and deductions? | 7

## Understanding payslips – the money

- **Gross pay** – this shows how much you will earn before any deductions
- **Deductions** – this is all the money taken from your salary before it is paid to you, e.g. income tax, NI contributions (which help you to qualify for social welfare payments such as Illness Benefit and State Pension), pension, student loan repayments
- **Net pay** – this is often known as take-home pay – it's your gross pay minus the deductions



## Planning for retirement – workplace pension

A **workplace pension** is offered by employers to the people who work for them.

Usually, workers agree to put a percentage of their monthly earnings into their pension, and the employer also puts some money into it.







## Analytical Cubism

Analytical Cubism - 1908-12—was about breaking down an object (like a bottle) viewpoint-by-viewpoint, into a fragmentary image. The subject was broken down into flattened planes and sharp angles with a limited colour palette.

## Synthetic Cubism

From around 1912 Braque, Picasso, and Gris, started to use simpler shapes and lines and brighter colours in their artworks. They also began to add **textures** and patterns to their work, often collaging **newspaper** or other patterned paper directly into their paintings. This approach was called **synthetic cubism**.

# Cubism

Cubism is a style of painting that was developed in the early 1900s. Cubist paintings show objects from many angles at once. Three main artists, **Pablo Picasso** and **Georges Braque**, and **Juan Gris** developed Cubism. They believed that painters should not just present realistic views of subjects.

These painters presented artworks which contained many viewpoints on the same 2D picture plane. This revolutionised the Art world and changed the idea of what art 'should look like' and what it should be about. The focus now moving away from realistic representation.

# Influences

The invention of photography in 1839 had a major impact upon the art that was made from that point on. Artists were no longer required to capture a likeness of a person ( portrait) and everyday scenes could now be recorded by a camera. So artists moved away from realistic representations and towards more abstract styles. **Paul Cezanne** was a major influence on the three main Cubist artists, **Pablo Picasso**, **Georges Braque** and **Juan Gris**. He believed that the world could be simplified down into basic shapes. As can be seen in these two landscapes.

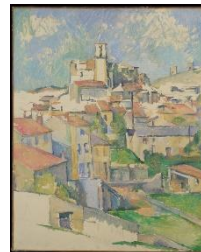

Word	Meaning
<b>Abstract</b>	Art that does not attempt to represent external reality, but rather seeks to achieve its effect using shapes, colours, and textures.
<b>Geometric</b>	Art which uses regular lines and shapes
<b>Simplify</b>	To make something simple and less complicated.
<b>Repetition</b>	Anything that is repeated.
<b>Analytical</b>	Looking carefully at something to see all of it's parts.
<b>Synthetic</b>	To synthesize or bring together different elements .



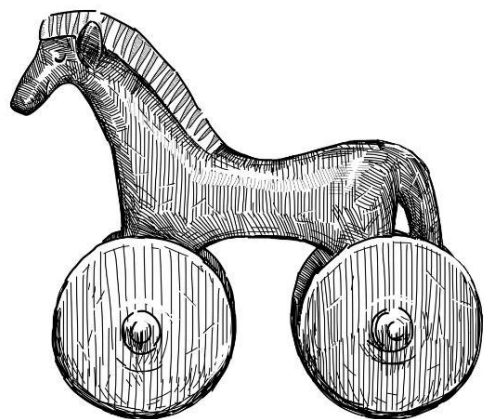

## Trojan Horse

Offers something tempting, either an attachment or a link - for example a funny video. When you open the attachment or click the link, it can install malware on your computer



## Hacking

Illegally accessing or modifying computer files without permission

## Logic bombs

A logic bomb tells the computer to execute a set of instructions at a certain data and time or under certain specified conditions.



## Phishing

Phishing is when someone pretends to be someone they are not, in order to get personal information from you



## Ransomware

Ransomware is software illegally installed on a computer so that the user cannot access their files until a ransom is paid

## Cybercrime



Many types of crime can be carried out with the aid of a computer. The victims can be governments, companies and organisations and you as individuals.

In 2017 the NHS and tens of thousands of other organisations around the world suffered a ransomware attack called "Wannacry"





## Virus

A virus is a type of **malware** (**MAL**icious Soft**WARE**). It **replicates** and installs itself without your consent. A virus can be **spread** to another computer through email or file sharing.



## How do people get caught if they commit a cybercrime?

Every online computer has an "IP address", this is like a computer's fingerprint.



## Health and safety

Back problems can arise from poor posture and sitting in one position for hours at a time. Repetitive strain injury (RSI) is caused by repeating the same action over and over again.

You could also get eye strain and headaches from staring at a screen for too long.

## Passwords

In 2016 hackers stole the login details of 272 million passwords from Gmail, Hotmail and Yahoo. 17% of those people used the password "123456"



## Copyright Law

Copyright law protects the owner of a creative work (art, music, literature etc.) from having it illegally copied. When you see the symbol above, it means that you are not allowed to copy or redistribute the work.



# Year 8 Design and Technology - Term 1B: Electronics

## Soldering Health and Safety

- The tip of the solder is hot
- ALWAYS follow instructions and rules.
- Do not take shortcuts.
- When you are not using the iron, return it the cradle.
- Tie back long hair.
- Do not flicker solder off the iron.
- Cut wires evenly.
- Wash your hands thoroughly after soldering.
- Always wear PPE, Safety goggles for your eyes.
- Make sure the solder is done on the soldering mat.

Scan the QR code to watch a video about soldering.



Key vocabulary	Definition
Parallel	Components are on different branches, if one breaks. The circuit keeps working.
Series	Components are on the same wire. If a component breaks, the circuit stops working.
Soldering	Soldering is a process of joining two or more metal pieces by melting and then filling the joint by a solder.
Voltage	Measurement of the electric potential or "pressure" at which electricity flows through a system.
Resistor	Restricts the flow of electrical current in a circuit.
Ohms	An electrical resistance between two points of a conductor when a constant potential difference of one volt.
Input/output	Input/output devices, as the name implies, are capable of delivering data (output) to and receiving data from a computer (input).
Components	The parts on a circuit, LED, batteries etc, are components.
LED	Light emitting diodes.
PCB	Printed Circuit Board, contained in all electronics

**Electronics**

Scan the QR code to watch a video about Electronics.

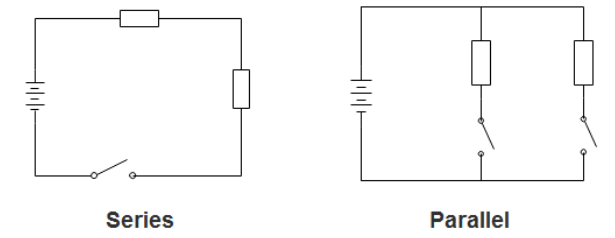

The types of Circuits

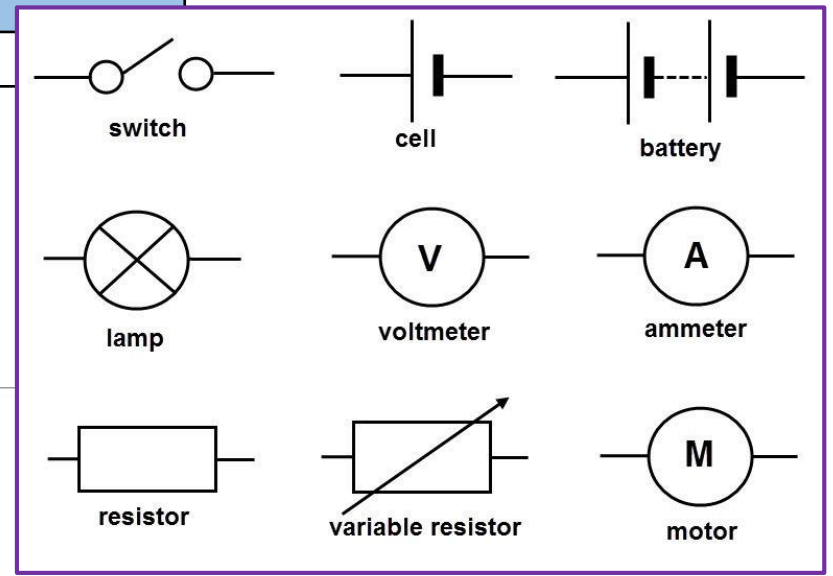
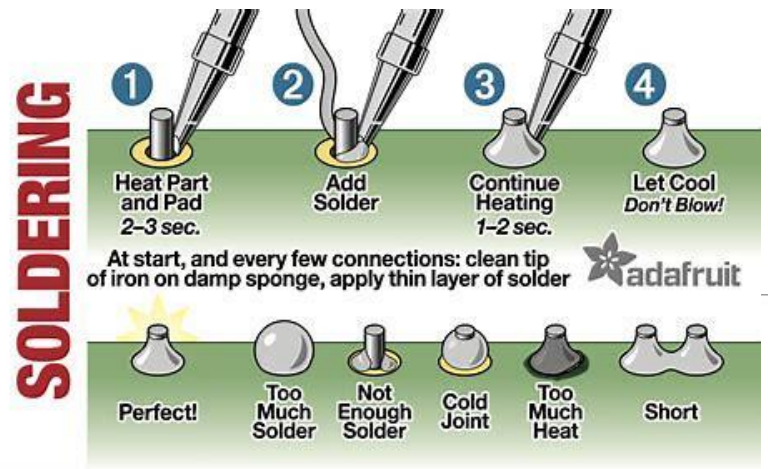

## Keywords and language

**Stimulus** : anything used to create or inspire ideas. A piece or writing, music, item

**Devising** : to create drama in response to a given stimulus

**Improvisation** : creating drama using no script

**Hotseating**: when someone asks questions of someone taking on a role and they answer as they character

**Re-enactment** : a moment that is re re-enacted or brought to life

**Research** : The process of finding out specific information for a specific purpose

**Abstract** : Meaning non naturalistic. Not like real life

**Analysis**: To break down and explain how and why you did something

**Evaluation**: To judge whether something was effective or not, using evidence

## Structuring Drama

**Linear** - continuous narrative where the events happen in chronological order

**Non linear** - moves backwards and forwards in time (flash backs/ flash forwards)

**Inter- connected stories** - A series of independent stories that link in some way

**Narration** - someone telling parts of the story, either in role or as a narrator

**Bookending**- having a link between the opening scene and the ending scene

**Three act structure**- having 3 clear parts to the story - start, middle, end.

**Cliff hanger** - left open ended or on a tense moment with unanswered questions

**Resolution** - giving a clear ending to the story

**Dramatic irony** - the audience being aware of something that the characters are not.

**Perspective** - The point of view that the story is told from

**Climax/ anti climax**- when the moments of tension are built up and then revealed

**Exposition** - When different characters are becoming involved in the same thing. Eg. All going for the same job interview.

**Complication** - a problem or obstacle that occurs for one of the characters



# Year 8 Food - Term 1B: Tasty savoury and sweet bakes

## Sensory evaluation

When you eat food you are judging the following characteristics:

- appearance
- taste
- smell - aroma
- texture - mouthfeel (how a food product feels in the mouth).

Sensory descriptors are used to describe foods.

**Appearance** = colourful, golden, lumpy, shiny, slimy, risen, soggy.

**Texture** = chewy, crispy, crumbly, dry, gooey, greasy, sticky, tender.

**Taste/smell** = acidic, bitter, bland, creamy, fruity, meaty, salty, sour, tangy, undercooked.

Scan the QR codes to watch a video about food safety and complete your homework quiz.

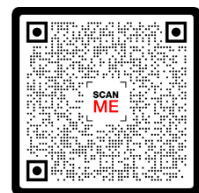

SCAN TO WATCH



SCAN FOR QUIZ

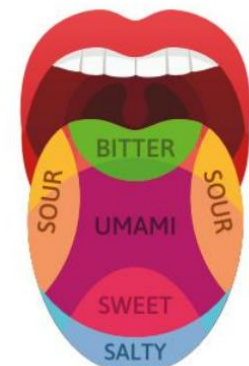

Key vocabulary	Definition
Appearance	How a food looks, including its colour. A burnt food does not look appetising.
Aroma	The smell of a food, it is easier to smell hot food than cold food.
Comparison	Part of sensory testing where foods are compared for their flavour.
Digestion	The parts of the body where food is broken down to provide nutrients.
Enzymes	Made from proteins they help us to digest our food.
Insulation	Fat is a macronutrient that helps keep us warm, this is known as insulation.
Rolling pin	Equipment used to flatten pastry and dough.
Sensory analysis	Testing food samples by tasting, touching and visual methods.
Sodium	A mineral that controls the amount of water in the body.
Taste	One of the senses, there are five different tastes (see diagram).

## Dough

A **dough** is a mixture of dry ingredients (such as flour) and liquid (such as water) that is mixed, kneaded, shaped and then baked.

**Pastry** is a mixture of flour, fat, and liquid, which is made into a dough. The fat and flour is rubbed together and liquid added. **Shortcrust** pastry does not rise, so it is used as a case to hold other ingredients. For example, jam tarts and quiche are made using shortcrust pastry.

## Macronutrients

Macronutrients are needed in large amounts by the body.

### Protein

Is needed for growth, repair, energy, maintenance (enzymes, hormones, antibodies).

Some people need more protein than others - children, pregnant women.

Made from amino acids.

Some amino acids have to come from food as your body cannot make them.

### Carbohydrate

Is needed for energy (should supply 50% of the energy for the day).

Three groups of carbohydrates are

- Starch
- Sugar
- Dietary fibre.

Fibre is essential for a healthy digestive system.

### Fat

Is needed for warmth, energy, protection, and providing fat soluble vitamins.

Fats may be:

- animal fats - butter, lard, suet, cream, hard cheese.
- vegetable fats - sunflower oil, olive oil, rapeseed oil, nuts.

## Reducing salt/fat/sugar

**Too much salt** can lead to high blood pressure, this can lead to a strain on the heart and kidneys, which will affect how efficiently they work.

**Too much fat** can lead to weight gain, which can eventually lead to obesity. It can also lead to coronary heart disease and stroke.

**Too much sugar** can lead to weight gain and dental caries (tooth decay).

Scan the QR codes to watch a video about the eight tips and complete your homework quiz.

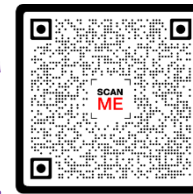

SCAN TO WATCH

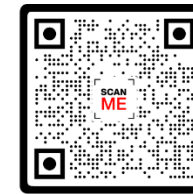

SCAN FOR QUIZ



St Cuthbert's Catholic High School  
Live life in all its fullness

# Year 8 Music - Term 1B: Reggae and Blues



• In the 1600s & 1700s, millions of Africans were captured and sold as slaves. Many were taken to North America.

• It is widely accepted that Blues music evolved from the African spirituals, chants, hymns, work songs and field hollers that were sung on the plantations.



• Over the years, African musical features such as Call & Response singing, blended with chords was the beginning of the Blues.

• Blues lyrics often deal with personal adversity. The Blues is also about overcoming hard luck, saying what you feel, ridding yourself of frustration.



• The best Blues music is visceral, cathartic and portrays genuine emotion.

## The Blues - Key Info

- Started around the 1920-30s
- From Southern USA
- Uses the [12 bar blues](#)
- Features [improvisation](#)
- Uses [call and response](#)
- Slow tempo
- Famous performers include Louis Armstrong, Bessie Smith, Billie Holiday, Robert Johnson and BB King.
- Instruments include piano, trumpet, double bass, drum kit, trombone, guitar and saxophone.



## Blues Chords and Roman Numerals

1. Whatever key you are in, count that as '1' (i.e. in C major, 1 is C)
2. From there, count up to 4 and 5 to work out what chords are IV and V (in C, IV is F and V is G)

### 12 bar Blues

12 Bar Blues Chord Progression in C

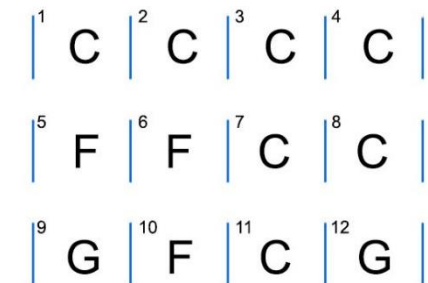

### Keywords

**Walking Bass line** - A walking bass line generally consists of notes of equal duration and intensity (typically 1/4 notes) that create a feeling of forward motion.

**12 bar blues** - The 12-bar blues (or blues changes) is one of the most prominent chord progressions in popular music.

**Triplets** - In music theory, a triplet is a three-note pattern that fills the duration of a typical two-note pattern.



# Year 8 Physical Education - Term 1B: The Skeletal System

## 'Types' of Bones in the Body

Type of bone	Example in body	Description
Long	Femur	Cylindrical in shape and found in the limbs. Their main function is to act as a lever.
Short	Carpals	Small and compact, often equal in length and width. These types of bone are designed for strength and weight bearing.
Flat	Ribs	Have a flat surface. Their function is for protection for the internal organs of the body.
Irregular bones	Vertebrae	Complex individual shapes, variety of functions including protection and muscle attachment.

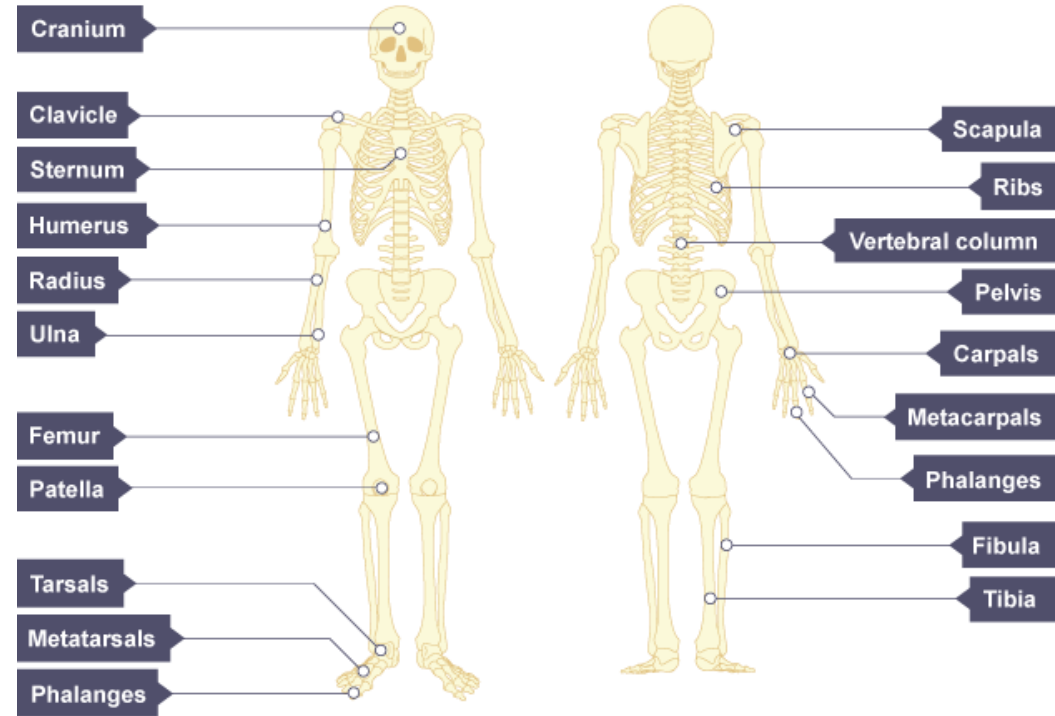

## The Functions of the skeletal system

- 1. Movement** - The bones act as levers and also form joints that allow muscles to pull on them and produce joint movements.
- 2. Support and protection** - the bones of the skeleton provide support for the body and also protect the organs found within it. For example, the cranium protects the brain.
- 3. Production of blood cells** - certain bones in the skeleton contain red bone marrow and the bone marrow produces red blood cells, white blood cells and platelets.

- 4. Storage of minerals** - the bones themselves are made of minerals and act as a mineral store for calcium and phosphorous, which can be given up if the body requires the minerals for other functions.
- 5. Attachment of muscles** - the bones of the skeleton provide surfaces for the attachment of muscles. This is why bones are often irregular shapes and have bony points and grooves to provide attachment points.





## Adjetivos claves:

- Enorme - enormous
- Grande - big
- Grandísimo - very big (muy grande)
- Espacioso - spacious
- Pequeño - small
- Pequeñísimo - very small (muy pequeño)
- Adosado - semi detached

- Moderno - modern
- Nuevo - new
- Antiguo - old
- Viejo - old
- Industrial - industrial
- Turístico - touristic
- Ruidoso - noisy
- Tranquilo - calm/ tranquil
- Feo- ugly
- Bonito- pretty

## Adverbios:

- Muy - very
- Un poco- a little
- bastante- quite
- demasiado- too

- Mi pueblo- my town
- Mi ciudad- my town
- Mi barrio- my neighbourhood
- Mi region- my region

## ¡Ojo!

You need to use the verb "estar" for location and the verb "ser" for descriptions.

Mi pueblo está en las afueras de Liverpool.

Mi pueblo es bastante gran moderno e industrial.



## C a R O L

The only letters that double in Spanish.



## Verbos claves en la forma infinitiva:

**Se puede + the infinitive**

- Se puede comer - you can eat
- Se puede beber - you can drink
- Se puede jugar - you can play
- Se puede comprar - you can buy
- Se puede ir - you can go
- Se puede ver- you can watch
- Se puede tomar - you can take/have
- Se puede visitar- you can visit

# Las tiendas/ los sitios de interés

## ¿Qué hay en tu pueblo?



### Vocabulario clave: sustantivos masculinos

El ayuntamiento- Town Hall  
El parque - park  
El estadio - stadium  
El teatro - theatre  
El cine - cinema  
El mercado- market  
El supermercado - supermarket  
El polideportivo - sports centre  
El campo de golf - golf course  
El museo - museum  
El zoológico - zoo  
El colegio- school  
El mercado- market

### Vocabulario clave: Sustantivos femeninos

La iglesia- church  
La panadería - bakery  
La pastelería - cake shop  
La frutería - grocery shop  
La farmacia - chemist  
La joyería - jewellery shop  
La tienda de ropa- clothes shop  
La zapatería - shoe shop  
La comisaría - police station  
La oficina de correos- post office  
La plaza de toros - bull ring  
La biblioteca- library  
La librería- book shop



Hay= There is  
/There are

sin embargo = however  
también = also  
porque = because  
donde = where  
pero = but  
con = with  
y = and

**¡Ojo!** When using the indefinite article "a" or "an" nouns begin with "un" or "una" When using the definite article "the" use "el" or "la" and in the plural forms "los" (mpl) and "las" (fpl)

¿Qué hay en tu pueblo? What is there in your town?  
En mi pueblo hay un parque, un cine y un supermercado también hay una oficina de correos.  
In my town there is a park, a cinema and a supermarket also there is a post office.

# Notes

A series of horizontal dotted lines for writing notes.





# **St Cuthbert's Catholic High School**

*Live life in all its fullness*